

# DL112X Alarm Sounder & Xenon Beacon

The DL112X is a high output, 119dB(A) alarm sounder with integrated 5 Joule Xenon beacon.

Low current consumption and high SPL in a robust IP66 enclosure ensure the DL112X is suitable for all general signalling applications including fire, security and process control. The corrosion proof, marine grade aluminium die cast enclosure is chromated and powder coated providing resilience in the harshest of industrial environments.

## Features

- High output, up to 119dB(A) SPL.
- 3 remotely selectable alarm stages.
- Choice of 45 alarm tone frequencies.
- Automatic synchronisation on multi-sounder system.
- 5 Joule, 200 candela Xenon beacon.
- Continuously rated.
- Stainless steel fixings.
- Duplicate cable terminations (in & out for daisy-chain installations).
- Tropicalisation available on request.
- Available with custom tone configurations and frequencies.
- Stage Programmable 4 stage/channel version available:
  - 45 alarm tones
  - 4 remotely selectable stages
  - Any tone can be assigned to any stage
  - User configurable continuous frequency tone

## Approvals

- UL & cULs approved: General signalling use.



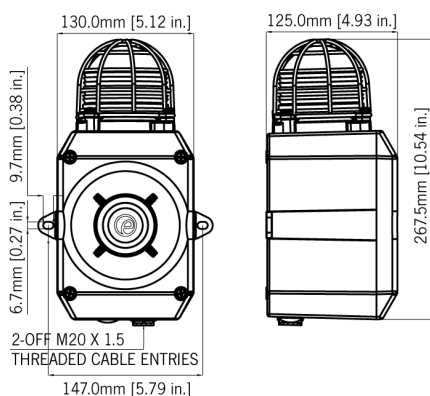

## Specification

### Sounder:

Maximum output:	119dB(A) @ 1 metre [110dB(A) @ 10ft/3m]
Nominal output:	112dB(A) @ 1m +/- 3dB - Tone 2 [103dB(A) @ 10ft/3m]
No. of tones:	45 (UKOOA / PFEER compliant)
No. of stages:	3
Volume control:	Max. 112dB(A); Min. 100dB(A) - Tone 2
Effective range:	125m/410ft @ 1KHz
Stage switching:	Negative Reverse polarity stage switching on DC units.

### Beacon:

Energy:	5 Joules (5Ws)
Flash rate:	1Hz (60 fpm)
Peak Candela:	500,000 cd - calculated from energy (J)
Effective Intensity cd:	250 cd - calculated from energy (J)
Peak Candela:	86,935 cd* - measured ref. to I.E.S.
Effective Intensity cd:	200 cd* - measured ref. to I.E.S.
Lens colours:	Amber, Blue, Clear, Green, Red & Yellow
Tube life:	Emissions are reduced to 70% after 5 million flashes

### General:

Voltages DC:	12Vdc; 24V dc; 48V dc [24V dc units can use 24V ac for single stage applications]
Voltages AC:	24V ac; 115V ac; 230V ac
Ingress protection:	IP66, Type 4 / 4X / 3R
Enclosure material:	Marine grade aluminium A1 Si 12 Cu
Enclosure colour:	Red (RAL3000), Grey (RAL7038)
Cable entries:	2 x M20 x 1.5mm threaded gland entries supplied with one stopping plug
Terminals:	0.5 to 4.0mm <sup>2</sup> cables.
Operating temp:	-25 to +55°C [-13° to +131°F]
Storage temp:	-40 to +70°C [-40° to +158°F]
Relative humidity:	90% at 20°C [68°F]
Weight:	DC: 2.80kg/6.16lbs AC:3.10kg/6.82lbs

\*Candela measurements representative of performance with clear lens at optimum voltage.

## Part Codes

Version:	Part code:
12V dc	DL112XDC012[x]/[y]
24V dc	DL112XDC024[x]/[y]
48V dc	DL112XDC048[x]/[y]
24V ac	DL112XAC024[x]/[y]
115V ac	DL112XAC115[x]/[y]
230V ac	DL112XAC230[x]/[y]

[x] = Enclosure colour: G: Grey R: Red

[y] - Lens colour: A: Amber, B: Blue, C: Clear, G: Green, R: Red, Y: Yellow

Suffix part number with 'P' for stage programmable, 4 stage, 45 tone version (not available with UL approval).

Suffix part number with 'UL' for UL approved version.

## Alarm Sounder

Version:		Voltage:	Current:
12V dc		10-30V dc	200mA*
24V dc		10-30V dc	200mA*
48V dc		35-60V dc	120mA*
24V ac	50/60Hz	+/-10%	500mA
115V ac	50/60Hz	+/-10%	100mA
230V ac	50/60Hz	+/-10%	60mA

\* current at nominal voltage on Tone 2

## Xenon Beacon

Version:		Voltage:	Current:
12V dc		10-14V dc	380mA
24V dc		20-28V dc	250mA
48V dc		42-54V dc	175mA
24V ac	50/60Hz	+/-10%	300mA
115V ac	50/60Hz	+/-10%	70mA
230V ac	50/60Hz	+/-10%	35mA

## Tone table

### S 1 Description

T 1	340 Hz Continuous
T 2	800/1000Hz @ 0.25 sec Alternating
T 3	500/1200Hz @ 0.3Hz 0.5 sec Slow Whoop
T 4	800/1000Hz @ 1Hz Sweeping
T 5	2400Hz Continuous
T 6	2400/2900Hz @ 7Hz Sweeping
T 7	2400/2900Hz @ 1Hz Sweeping
T 8	500/1200/500Hz @ 0.3Hz Sweeping
T 9	1200/500Hz @ 1Hz - DIN / PFEER P.T.A.P.
T 10	2400/2900Hz @ 2Hz Alternating
T 11	1000Hz @ 1Hz Intermittent
T 12	800/1000Hz @ 0.875Hz Alternating
T 13	2400Hz @ 1Hz Intermittent
T 14	800Hz 0.25sec on, 1 sec off Intermittent
T 15	800Hz Continuous
T 16	660Hz 150mS on, 150mS off Intermittent
T 17	544Hz (100mS)/440Hz (400mS) - NF S 32-001
T 18	660Hz 1.8sec on, 1.8sec off Intermittent
T 19	1.4KHz-1.6KHz 1s, 1.6KHz-1.4KHz 0.5s -NFC48-265
T 20	660Hz Continuous
T 21	554Hz/440Hz @ 1Hz Alternating
T 22	544Hz @ 0.875 sec. Intermittent
T 23	800Hz @ 2Hz Intermittent
T 24	800/1000Hz @ 50Hz Sweeping
T 25	2400/2900Hz @ 50Hz Sweeping
T 26	Bell
T 27	554Hz Continuous
T 28	440Hz Continuous
T 29	800/1000Hz @ 7Hz Sweeping
T 30	300Hz Continuous
T 31	660/1200Hz @ 1Hz Sweeping
T 32	Two T chime.

### S 1 Description

T 33	745Hz @ 1Hz Intermittent
T 34	1000 & 2000Hz @ 0.5 sec Alternating - Singapore
T 35	420Hz @ 0.625 sec Australian Alert
T 36	500-1200Hz 3.75sec /0.25sec. Australian Evac.
T 37	1000Hz Continuous - PFEER Toxic Gas
T 38	2000Hz Continuous
T 39	800Hz 0.25sec on, 1 sec off Intermittent
T 40	544Hz (100mS)/440Hz (400mS) - NF S 32-001
T 41	Motor Siren - slow rise to 1200 Hz
T 42	Motor Siren - slow rise to 800 Hz
T 43	1200 Hz Continuous
T 44	Motor Siren - slow rise to 2400 Hz
T 45	1KHz 1s on, 1s off Intermittent - PFEER Gen. ...