

AL112NH Alarm Horn Sounder & LED Beacon

The AL112NH features the 119dB(A) A112N alarm horn sounder combined with the L101H high output L.E.D. beacon.

Features

- High output L.E.D array
- Automatic synchronisation on multi-sounder system.
- Continuously rated.
- Stainless steel fixings.
- Unit can be mounted using external lugs or internal BESA compatible fixing positions.
- Duplicate cable terminations (in & out for daisy-chain installations).
- Tropicalisation available on request.
- Available with custom tone configurations and frequencies.
- Stage Programmable 4 stage/channel version available:
 - 45 alarm tones
 - 4 remotely selectable stages
 - Any tone can be assigned to any stage
 - User configurable continuous frequency tone

Approvals

- Alarm sounder (A112N): EN54-3 (CPD 89/106/EEC).
- UL & cULs approved: General signalling use.
- GOST-R approved: POCC GB-JB05-H0014.



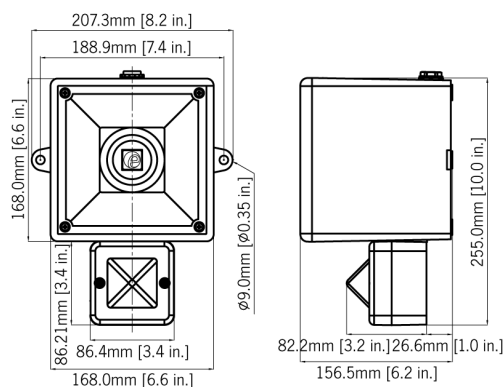

Specification

Sounder:

Maximum output:	119dB(A) @ 1 metre [110dB(A) @ 10ft/3m]
Nominal output:	112dB(A) @ 1m +/- 3dB - Tone 2 [103dB(A) @ 10ft/3m]
No. of tones:	45 (UK00A / PFEER compliant)
No. of stages:	3
Volume control:	Max. 112dB(A); Min. 100dB(A) - Tone 2
Effective range:	125m/410ft @ 1KHz
Voltages DC:	24V dc (10-30Vdc)
Voltages AC:	115V ac; 230V ac
Stage switching:	Negative Reverse polarity stage switching on DC units.

Beacon:

Light source:	High intensity L.E.D. array. 24 x Superflux type high output L.E.D's
Options:	Steady or 2Hz flash mode (on board selection)
Peak/Effective Intensity cd:	Green L.E.D: 176cd - measured ref. to I.E.S.
Terminals:	0.5 to 4.0mm ² cables
L.E.D. colours:	Amber Blue, Green, Red and White
Lens colour:	All L.E.D. colours use a Clear lens to maximise output and to ensure the signal is most effective in high ambient light

General:

Ingress protection:	IP66	High impact
Enclosure material:		UL94 V0 & 5VA FR ABS
Enclosure colour:	Red (RAL3000)	
Cable entries:	2 x M20 clearance gland entries in side & back	
Terminals:	0.5 to 4.0mm ² cables.	
Operating temp:	-25 to +55°C [-13° to +131°F]	
Storage temp:	-40 to +70°C [-40° to +158°F]	

Part Codes

Version:	Part code:
24V dc	AL112NHDC024[x]/[y]
115V ac	AL112NHAC115[x]/[y]
230V ac	AL112NHAC230[x]/[y]

[x] = Enclosure colour: R: Red G: Grey A: Amber, B: Blue. W: Clear (White), G: Green, R: Red
[y] = Lens colour: Green, R: Red

Note: To maximise output in high ambient light environments the AL112NH uses clear lenses for all L.E.D colours.

Suffix part number with 'P' for stage programmable, 4 stage, 45 tone version (not available with UL approval). Suffix part number with 'UL' for UL approved version.

Alarm Sounder

Version:	Voltage:	Current:
24V dc	10-30V dc	200mA*
115V ac	50/60Hz +/-10%	100mA
230V ac	50/60Hz +/-10%	60mA

* current at nominal voltage on Tone 2

L.E.D. Beacon

Version:	Voltage:	Current:
24V dc	10-30V dc	155mA (@ 24V dc)
115/230V ac	90-260V	35mA (@230V ac)
50/60Hz	ac/dc	

Tone table

S 1 Description

T 1	340 Hz Continuous
T 2	800/1000Hz @ 0.25 sec Alternating
T 3	500/1200Hz @ 0.3Hz 0.5 sec Slow Whoop
T 4	800/1000Hz @ 1Hz Sweeping
T 5	2400Hz Continuous
T 6	2400/2900Hz @ 7Hz Sweeping
T 7	2400/2900Hz @ 1Hz Sweeping
T 8	500/1200/500Hz @ 0.3Hz Sweeping
T 9	1200/500Hz @ 1Hz - DIN / PFEER P.T.A.P.
T 10	2400/2900Hz @ 2Hz Alternating
T 11	1000Hz @ 1Hz Intermittent
T 12	800/1000Hz @ 0.875Hz Alternating
T 13	2400Hz @ 1Hz Intermittent
T 14	800Hz 0.25sec on, 1 sec off Intermittent
T 15	800Hz Continuous
T 16	660Hz 150mS on, 150mS off Intermittent
T 17	544Hz (100mS)/440Hz (400mS) - NF S 32-001
T 18	660Hz 1.8sec on, 1.8sec off Intermittent
T 19	1.4KHz-1.6KHz 1s, 1.6KHz-1.4KHz 0.5s -NFC48-265
T 20	660Hz Continuous
T 21	554Hz/440Hz @ 1Hz Alternating
T 22	544Hz @ 0.875 sec. Intermittent
T 23	800Hz @ 2Hz Intermittent
T 24	800/1000Hz @ 50Hz Sweeping
T 25	2400/2900Hz @ 50Hz Sweeping
T 26	Bell
T 27	554Hz Continuous
T 28	440Hz Continuous
T 29	800/1000Hz @ 7Hz Sweeping
T 30	300Hz Continuous
T 31	660/1200Hz @ 1Hz Sweeping
T 32	Two T chime.

S 1 Description

T 33	745Hz @ 1Hz Intermittent
T 34	1000 & 2000Hz @ 0.5 sec Alternating - Singapore
T 35	420Hz @ 0.625 sec Australian Alert
T 36	500-1200Hz 3.75sec /0.25sec. Australian Evac.
T 37	1000Hz Continuous - PFEER Toxic Gas
T 38	2000Hz Continuous
T 39	800Hz 0.25sec on, 1 sec off Intermittent
T 40	544Hz (100mS)/440Hz (400mS) - NF S 32-001
T 41	Motor Siren - slow rise to 1200 Hz
T 42	Motor Siren - slow rise to 800 Hz
T 43	1200 Hz Continuous
T 44	Motor Siren - slow rise to 2400 Hz
T 45	1KHz 1s on, 1s off Intermittent - PFEER Gen. ...