

AL105NH Alarm Horn Sounder & LED Beacon

The AL105NH features the 112dB(A) A105N alarm horn sounder combined with the L101H high output L.E.D. beacon.

The array of 24 Superflux type high output L.E.D.'s generates over 120 candela of light output and can be user set to either steady or flashing mode. Sounder & beacon may be connected from a single supply for simultaneous operation or from separate supplies for independent operation. The robust, fire retardant IP66 housing ensures the AL105NH is suitable for all general signalling applications.

Features

- High output L.E.D array
- Automatic synchronisation on multi-sounder system.
- Continuously rated.
- Stainless steel fixings.
- Unit can be mounted using external lugs or internal BESA compatible fixing positions.
- Duplicate cable terminations (in & out for daisy-chain installations).
- Tropicalisation available on request.
- Available with custom tone configurations and frequencies.
- Stage Programmable 4 stage/channel version available:
 - 45 alarm tones
 - 4 remotely selectable stages
 - Any tone can be assigned to any stage
 - User configurable continuous frequency tone

Approvals

- Alarm sounder (A105N): EN54-3 (CPD 89/106/EEC).
- GOST-R approved: POCC GBJB05-B02228.
- UL & cULs approved: General signalling use.



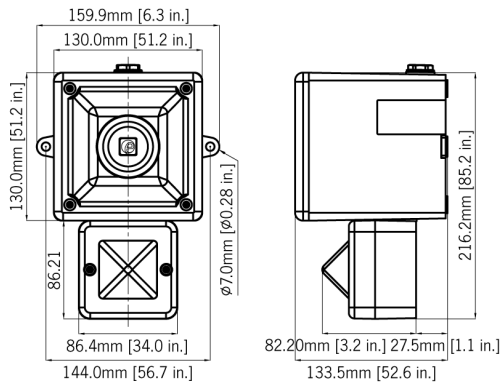

Specification

Sounder:

Maximum output:	112dB(A) @ 1 metre [103dB(A) @ 10ft/3m]
Nominal output:	105dB(A) @ 1m +/- 3dB - Tone 2* [96dB(A) @ 10ft/3m]
No. of tones:	32 (UK00A / PFEER compliant)
No. of stages:	3
Volume control:	Max. 105dB(A); Min. 96dB(A) - Tone 2
Effective range:	60m/197ft @ 1KHz
Stage switching:	Negative Reverse polarity stage switching on DC units.

Beacon:

Light source:	High intensity L.E.D. array. 24 x Superflux type high output L.E.D's
Options:	Steady or 2Hz flash mode (on board selection)
Peak/Effective Intensity cd:	Green L.E.D: 176cd - measured ref. to I.E.S.
Terminals:	0.5 to 4.0mm ² cables
L.E.D. colours:	Amber Blue, Green, Red and White
Lens colour:	All L.E.D. colours use a Clear lens to maximise output and to ensure the signal is most effective in high ambient light

General:

Voltages DC:	24V dc (10-30V dc)
Voltages AC:	115V ac; 230V ac
Ingress protection:	IP66
Enclosure material:	High impact UL94 V0 & 5VA FR ABS
Enclosure colour:	Red (RAL3000), grey (RAL7038) & white.
Cable entries:	2 x M20 clearance gland entries in side & back
Terminals:	0.5 to 1.5mm ² cables.
Operating temp:	-25 to +55°C [-13° to +131°F]
Storage temp:	-40 to +70°C [-40° to +158°F]
Relative humidity:	90% at 20° [68°F]
Weight:	DC: 0.95kg/2.09lbs AC: 1.20kg/2.64lbs

*Candela measurements representative of performance with clear lens at optimum voltage.

*SPL data +/-3dB(A). Measured at optimum voltage.

Part Codes

Version:	Part code:
24V dc	AL105NHDC024[x]/[y]
115V ac	AL105NHAC115[x]/[y]
230V ac	AL105NHAC230[x]/[y]
[x] = Enclosure colour:	G: Grey, R: Red
[y] = L.E.D colour:	A: Amber, B: Blue, W: Clear (White) G: Green, R: Red

Note: To maximise output in high ambient light environments the AL 105NH uses clear lenses for all L.E.D colours.

Suffix part number with 'P' for stage programmable, 4 stage, 45 tone version (not available with UL approval).
Suffix part number with '-UL' for UL approved version.

Alarm Sounder

Version:	Voltage:	Current:
24V dc	10-30V dc	25mA*
115V ac	50/60Hz +/-10%	20mA
230V ac	50/60Hz +/-10%	15mA

* current at nominal voltage on Tone 2

L.E.D. Beacon

Version:	Voltage:	Current:
24V dc	10-30V dc	155mA (@ 24V dc)
115/230V ac	90-260V	35mA (@230V ac)
50/60Hz	ac/dc	

Tone table

S 1 Description

S 1 Description	S 2	S 3
T 1 340 Hz Continuous	T 2	T 5
T 2 800/1000Hz @ 0.25 sec Alternating	T 17	T 5
T 3 500/1200Hz @ 0.3Hz 0.5 sec Slow Whoop	T 2	T 5
T 4 800/1000Hz @ 1Hz Sweeping	T 6	T 5
T 5 2400Hz Continuous	T 3	T 20
T 6 2400/2900Hz @ 7Hz Sweeping	T 7	T 5
T 7 2400/2900Hz @ 1Hz Sweeping	T 10	T 5
T 8 500/1200/500Hz @ 0.3Hz Sweeping	T 2	T 5
T 9 1200/500Hz @ 1Hz - DIN / PFEER P.T.A.P.	T 15	T 2
T 10 2400/2900Hz @ 2Hz Alternating	T 7	T 5
T 11 1000Hz @ 1Hz Intermittent	T 2	T 5
T 12 800/1000Hz @ 0.875Hz Alternating	T 4	T 5
T 13 2400Hz @ 1Hz Intermittent	T 15	T 5
T 14 800Hz 0.25sec on, 1 sec off Intermittent	T 4	T 5
T 15 800Hz Continuous	T 2	T 5
T 16 660Hz 150mS on, 150mS off Intermittent	T 18	T 5
T 17 544Hz (100mS)/440Hz (400mS) - NF S 32-001	T 2	T 27
T 18 660Hz 1.8sec on, 1.8sec off Intermittent	T 2	T 5
T 19 1.4KHz-1.6KHz 1s, 1.6KHz-1.4KHz 0.5s -NFC48-265	T 2	T 5
T 20 660Hz Continuous	T 2	T 5
T 21 554Hz/440Hz @ 1Hz Alternating	T 2	T 5
T 22 544Hz @ 0.875 sec. Intermittent	T 2	T 5
T 23 800Hz @ 2Hz Intermittent	T 6	T 5
T 24 800/1000Hz @ 50Hz Sweeping	T 29	T 5
T 25 2400/2900Hz @ 50Hz Sweeping	T 29	T 5
T 26 Bell	T 2	T 15
T 27 554Hz Continuous	T 26	T 5
T 28 440Hz Continuous	T 2	T 5
T 29 800/1000Hz @ 7Hz Sweeping	T 7	T 5
T 30 300Hz Continuous	T 2	T 5
T 31 660/1200Hz @ 1Hz Sweeping	T 26	T 5
T 32 Two T chime.	T 26	T 15